

# **TELPAR**

## **SP-328 Data Logger Thermal Printer**



**For Sales, Technical Support, Warranty Returns and Repairs, please contact us at**

**800-872-4886**

**Please visit our website at any time at**

**[www.telpar.com](http://www.telpar.com)**

## Table of Contents

---

<b>Section 1. INTRODUCTION</b>	<b>2</b>
<hr/>	
<b>Section 2. OPERATOR INFORMATION</b>	<b>3</b>
<hr/>	
2.1 Printer Front Panel Layout.....	3
2.2 Unpacking and Inspection.....	4
2.3 Paper Loading.....	5
<b>Section 3. INSTALLATION</b>	<b>6</b>
<hr/>	
3.1 Power Up and Self Test.....	6
<b>Section 4. INTERFACE SPECIFICATIONS</b>	<b>7</b>
<hr/>	
4.1 Serial Interface Specifications.....	7
DB-9 RS-232 Serial Interface.....	7
WECO Connector RS-232 Serial Interface.....	7
4.2 Parallel Interface.....	8
4.3 Flow Control.....	8
4.4 Parallel Interface Cable.....	9
<b>Section 5. PROGRAMMING INFORMATION</b>	<b>10</b>
<hr/>	
5.1 Control Codes and Escape Sequences.....	10
<b>Section 6. MAINTENANCE</b>	<b>11</b>
<hr/>	
6.1 Introduction.....	11
6.2 Required Tools and Supplies.....	11
6.3 Cleaning.....	11
6.4 Printing and Malfunctions.....	11
6.5 Maintenance Chart.....	11
<b>APPENDIX</b>	<b>12</b>
<hr/>	
Appendix A. ASCII Codes.....	12
Appendix B Printer Specifications.....	13
Appendix C Dimensions.....	14

## **Section 1. INTRODUCTION**

**The TELPAR SP-328 is a fast, low cost, narrow 40 column industrial printer. The SP-328 will print at a paper feed rate of 1.3 inches per second. .**

**The SP-328 can provide a variety of output formats on the standard 2.350" wide thermal paper. Standard programming includes 11X28, and 22X28 dot matrix characters The SP-328 is also capable of high density graphics MTBF = 107 Pulses (printing rate 25%). The SP-328 is equipped with a standard 9 pin RS-232, WECO 4 Position RS-232, and a Centronics type parallel interface.**

**Low maintenance is assured by TELPAR's reliable design, ribbonless thermal print technology. The SP-328 also includes a built-in diagnostic self test and a 31K data buffer).**

**The printer weighs 4.5 pounds including the paper supply and mounting frame. It is housed in a rugged 16 gage steel enclosure. It operates through -40° to +140° F with a constantly regulated print intensity control.**

## Section 2. OPERATOR INFORMATION

### 2.1 Printer Front Panel Layout

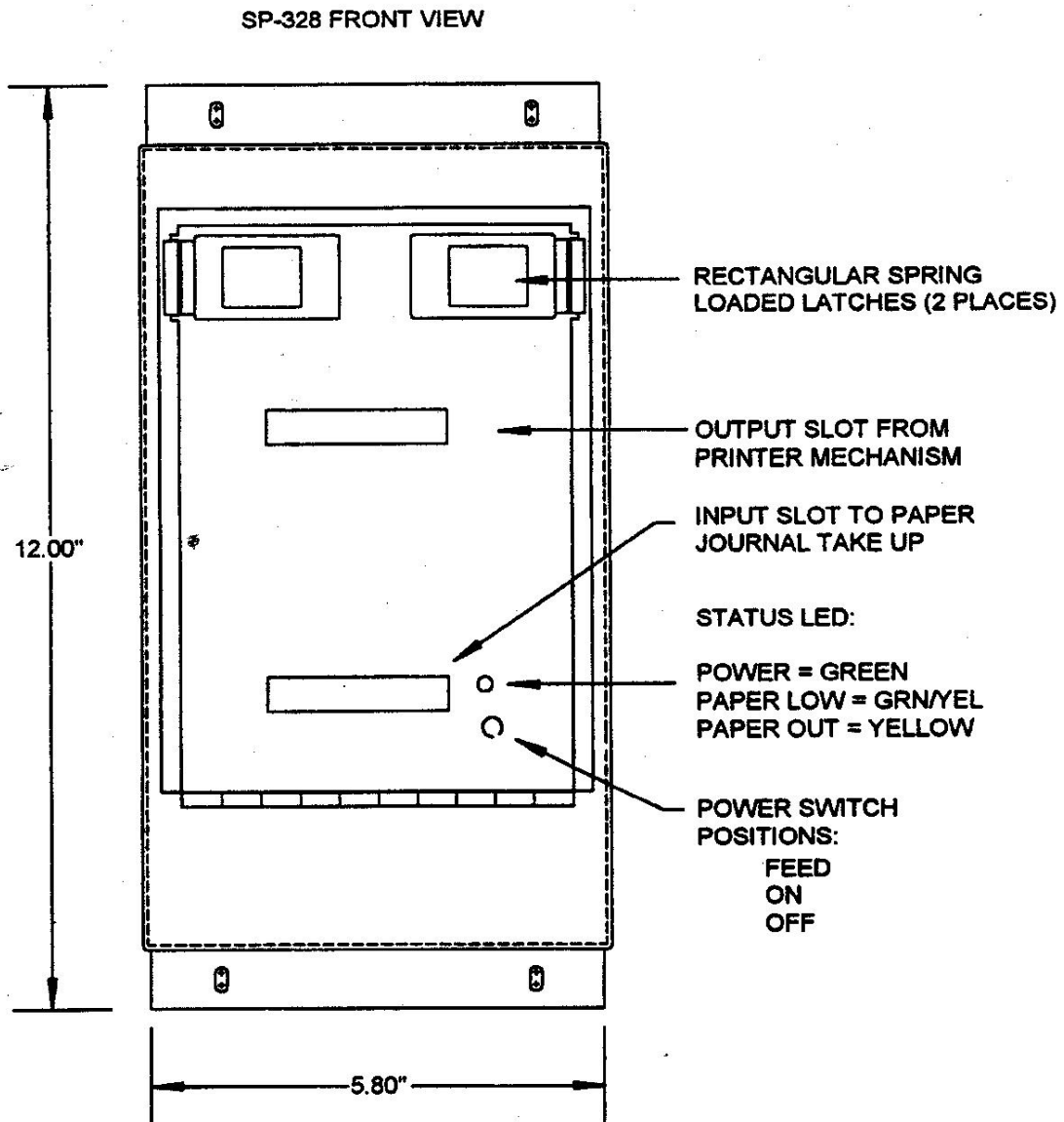

## 2.2 Unpacking and Inspection

Carefully unpack and inspect your SP-328 for any damage which may have occurred in transit. Should any damage have occurred, notify Telpar. Specify the nature and extent of the damage. Before installing or operating the printer, check the following:

1. Ensure that the primary power setting is correct for your installation.
2. Ensure that the printer mechanism and paper path are clear of all packing material; other foreign matter.
3. Ensure that paper is installed. **DO NOT OPERATE** the printer without paper. Refer to Section 2.3 for paper loading instructions.

The printed circuit board is where the main fuse, (F1) is located.

F1 = PCC1-5 Amp

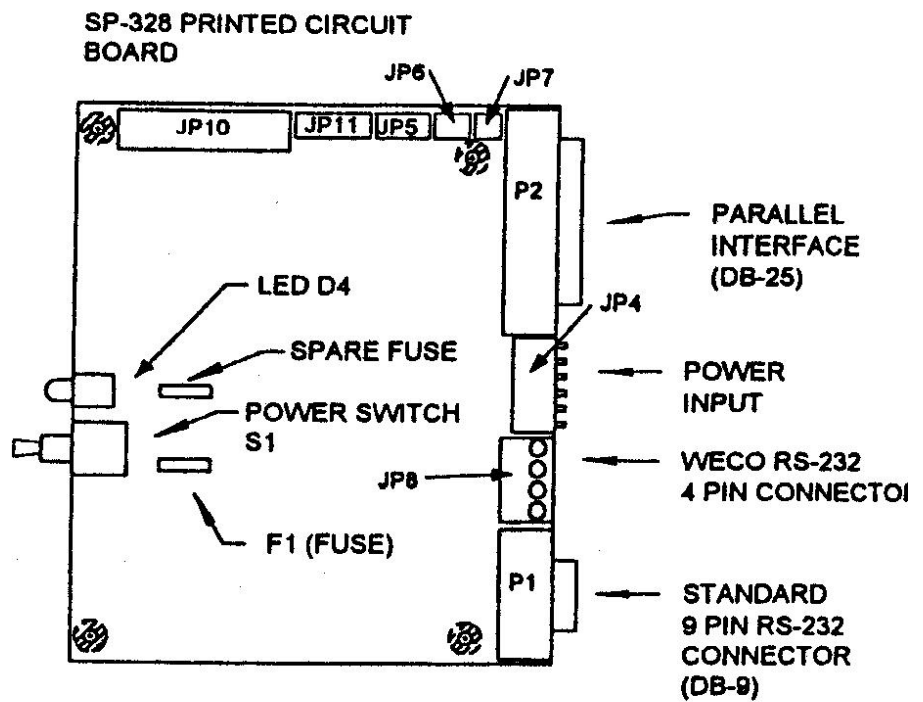

## 2.3 Paper Loading

To allow access to the printer paper supply, push the spring loaded rectangular latches inward (together) and pull forward to release the printer access panel. Install a new roll of Telpar approved paper (thermal side UP) on the paper spindle. Fold paper back on itself to form a straight and clean edge, and feed the leading edge of the paper directly into the paper input slot. The paper will automatically feed paper through the mechanism several inches. Use the power switch in the feed position to advance paper through the bottom take-up slot in the bezel – feed an appropriate amount of paper through the printer to allow the installation of the paper onto the Paper Take Up Journal.

To load paper onto the take up, unscrew the fastener holding the left side guide plate and pinch rod. Install paper between the main take up shaft and pinch bar and screw the fastener back onto the take up spindle. Manually rotate the take up mechanism as shown to remove excess slack in the paper.

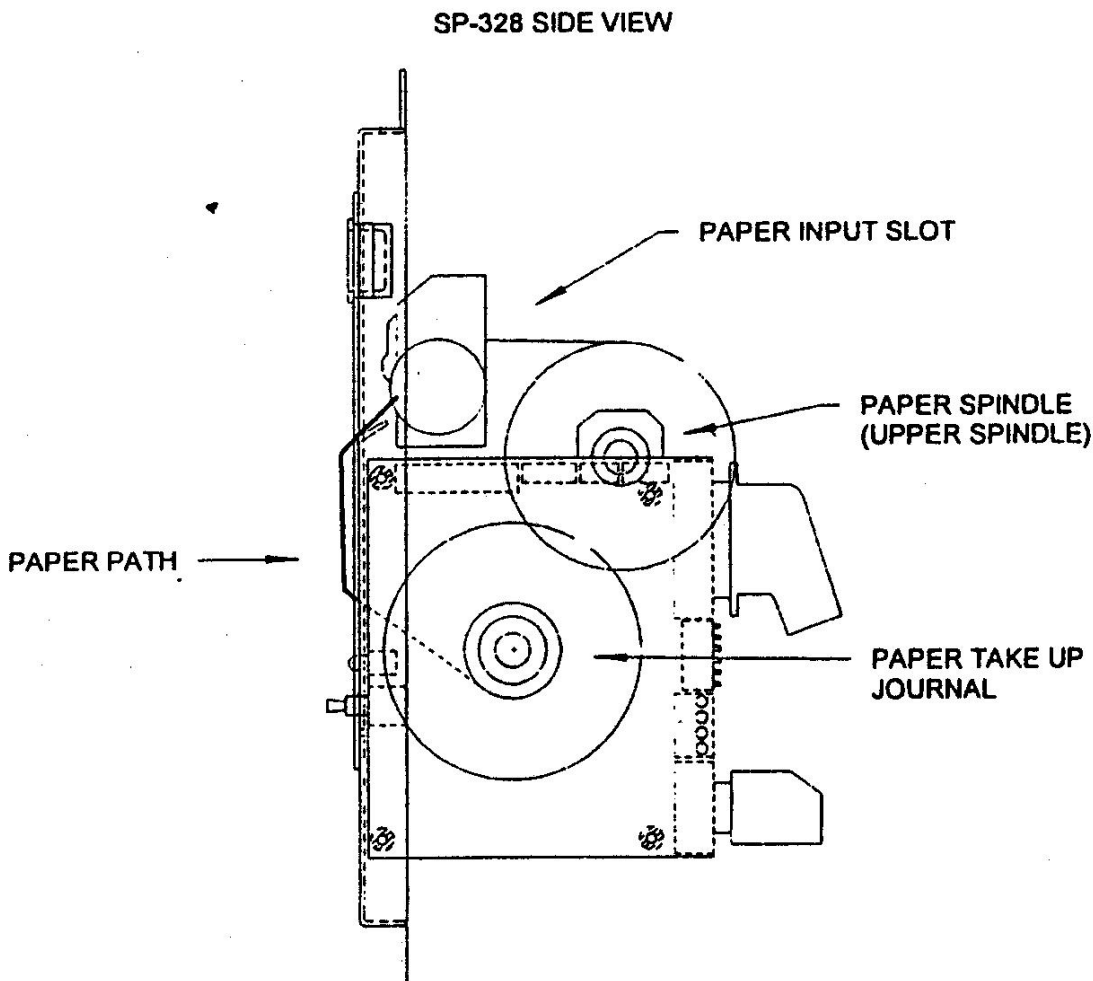

## Section 3. INSTALLATION

### 3.1 Power Up and Self Test

The operating controls of the SP-328 have been kept to a minimum. A convenient self-test feature allows the operator to quickly determine that the printer is operating correctly.

The switch functions as shown below:

SWITCH POSITION	FUNCTION
TOP	Paper Feed / Self Test
MIDDLE	Power On
LOWER	Power Off

POWER CONNECTOR PIN DESIGNATIONS

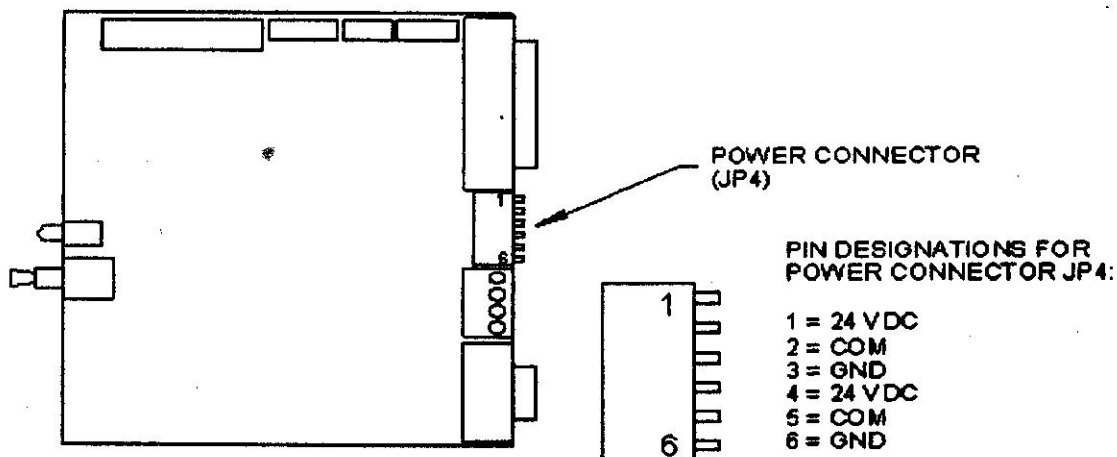

To activate the self test feature, toggle the power switch from the off position to the feed position and hold until the self test begins. The SP-328 enters self test mode and prints out an alpha/numeric test pattern.

For the highest quality output and maximum thermal headlife, it is recommended that only Telpar qualified thermal paper is used.

TELPAR SP-328 Thermal Paper Part #: 751328-0030 (3 inch diameter roll)

## Section 4. INTERFACE SPECIFICATIONS

### 4.1 Serial Interface Specifications

The SP-328 can be used as either a serial or parallel device without requiring any switch or jumper settings. The SP-328 will automatically detect the interface which is sending data and produce the appropriate printout. The serial interface parameters are factory set internal to the printer firmware. Serial interface parameters must be specified prior to shipment. The standard factory setting for the RS-232 serial interface is 9600 Baud, No Parity, 8 Data Bits, 1 Stop Bits.

#### DB-9 RS-232 Serial Interface:

The serial interface is a DB-9 connector with the following pin assignments:

Pin	Signal	Description
1	GROUND	Chassis ground
2	TXD	Data output from the printer to the host
3	RXD	Data input to the printer, (20 mA input - optional)
4	CTS	Inhibits TXD line when held at -10v by the host
5	GROUND	Signal ground
8	BUSY	-10v when printer is unable to receive data
9	RETURN	(20 mA return line - optional)

#### WECO Connector RS-232 Serial Interface:

Pin	Signal	Description
1	TXD	Data output from the printer to the host
2	RXD	Data input to the printer or display
3	GROUND	Signal ground
4	BUSY	-10v when printer is unable to receive data

There are two conventions used in the RS-232C interface; these are Data Terminal Equipment (DTE) and Data Communications Equipment (DCE). Examples of DCE are modems, multiplexers, and telephone data line interfaces. All other equipment which originates or receives data such as terminals (including the SP-328) or computers is DTE. If two pieces of DTE are to be interconnected it is necessary to transpose TXD and RXD as well as DTR and CTS in the cable. This type of cable is called a null modem cable and must be used if the SP-328 is connected to a host computer's serial port.



## 4.2 Parallel Interface

A DB 25S connector is used for the parallel interface. The SP-328 can be used as either a serial or parallel device without requiring any switch or jumper settings. The SP-328 will automatically detect the interface which is sending data and produce the appropriate printout. The pin assignments and brief signal descriptions are listed below.

Pin	Signal	Description
1	STROBE	1 $\mu$ sec. pulse to clock data into the printer
2	DATA 0	Eight data bit input signals to the printer; Signal levels are high for logic 1 and low for a logic 0.
3	DATA 1	
4	DATA 2	
5	DATA 3	
6	DATA 4	
7	DATA 5	
8	DATA 6	
9	DATA 7	
10	ACK	6 $\mu$ sec pulse from printer when data received
11	BUSY	High when printer is unable to receive data
12	PE	High when a paper error occurs in printer
13	SELECT	High when printer is on line
18-25	GROUND	Signal Grounds

## 4.3 Flow Control

The SP-328 employs a 31 K byte data buffer to allow the host computer to rapidly transfer data. Under some circumstances it may be possible to completely fill the buffer. When the buffer is within 50 bytes of being full, the SP-328 signals the host computer to pause until a line of data is printed, or until the buffer is under the 50 byte limit. The flow control information is sent to the host using hardware and software protocols.

The hardware protocol uses the BUSY line of the parallel interface and the BUSY line of the serial interface. These pins are asserted or negated as necessary to turn off and turn on the flow of data. There is an optional (factory set internal to the printer firmware) software protocol for RS-232 serial which uses the XON and XOFF ASCII characters (^Q and ^S) which are sent back to the host to start and stop the data stream. Some host systems may not support one or both of these protocols.

#### 4.4 Parallel Interface Cable

This parallel cable configuration is used to interface the SP-328 with all IBM and IBM compatible systems. This cable connects the interface to the printer with a 1:1 cable connection, and is terminated by a DB-25P on each end. This 25 pin cable configuration is available at most computer supply stores. ex. pin 1 to pin 1, pin 2 to pin 2,...pin 25 to pin 25.

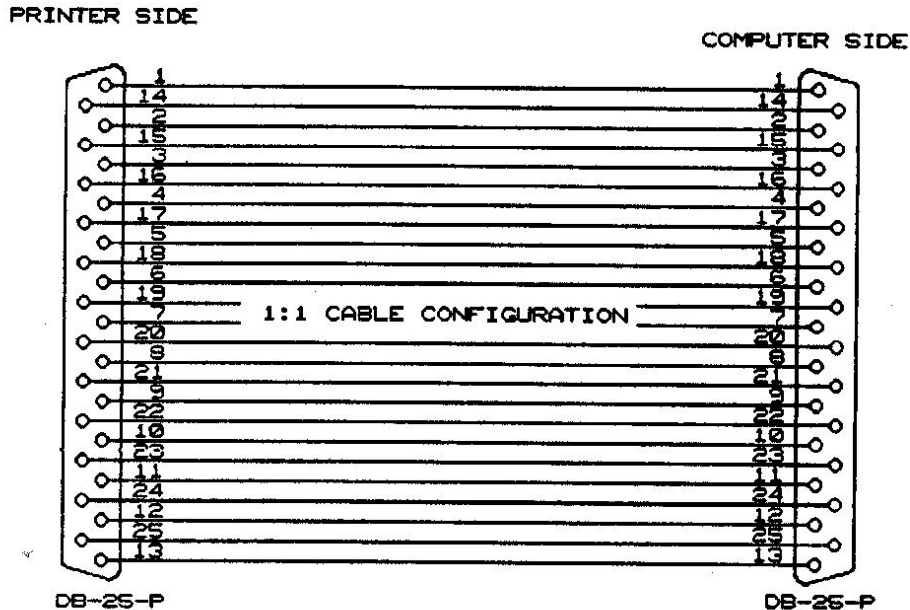

**Please Note:**

Cable length for the standard mode of parallel printing (through MS-DOS) should be limited to 25 feet or less.

**If using a windows operating system:**

- 1) Disable the quick print to port feature.  
This is located under the print manager.
- 2) Cable length should not exceed 6 feet.

## Section 5. PROGRAMMING INFORMATION

### 5.1 Control Codes and Escape Sequences

CATEGORY	SYMBOL	DECIMAL (HEX)	FUNCTION
<b>Control Code</b> * Valid for one line only. Returns to Serif Character Set after Carriage Return.			
	PLSET *	02 (02)	Plain Character Set
	PLBOLD *	03 (03)	Plain Bold Character Set
	SLF	10 (0A)	Single Line Feed
	Print	13 (0D)	Carriage Return
	SO	14 (0E)	Double Wide Print On
	SI	15 (0F)	Double Wide Print Off
	DC2 *	18 (12)	Reverse Video
	DC3 *	19 (13)	Serif Bold Character Set
	CAN	24 (18)	Clear All Buffers
	ESC	27 (1B)	Escape
<b>ESC Sequence</b>			
	ESC,3,n	51,n (33),n	Set Line Spacing to n/216" n=25-255
	ESC,h,n	104 (68),n	Horizontal Graphics Tab n=1-255
	ESC,j,n	106 (6A),n	Line Feed in Horiz. Graphics n=1-255
	ESC,l,n	108 (6C),n	Horizontal Graphics n=1-255

## **Section 6. MAINTENANCE**

### **6.1 Introduction**

The SP-328 printer is designed to require a minimum of maintenance and service. This section provides instructions for cleaning and maintenance. Electrical and mechanical repairs should be performed by qualified personnel only. Make certain that all electrical connections are disconnected before any service is performed on the SP-328.

### **6.2 Required Tools and Supplies**

1. Common hand tools
2. Volt-Ohm meter
3. Denatured alcohol
4. Cleaning rags
5. Cotton swabs
6. Lubricant IBM #23, LUBRIPLATE #70, SILCON #35

### **6.3 Cleaning**

The SP-328 exterior cabinet may be cleaned with a non-abrasive cleanser. Care should be taken to prevent liquids from entering inside the mechanical assembly. If in a dirty environment the mechanism may be cleaned with alcohol and a cotton swab. The mechanism may also be "blown out" with compressed air. Do not direct air flow directly to the printer platen, this may damage the printing surface on the platen. When the mechanism is clean and free of dirt, a light silicon lubricant may be applied (sparingly) to the moving mechanical components.

### **6.4 Printing Malfunctions**

Examples of Printing Problems (Cause and Effect)

Poor Print Quality	<ul style="list-style-type: none"> <li>• Dirty Thermal Print Mechanism/Head</li> <li>• Worn Print Head</li> <li>• Poor Quality Thermal Paper</li> <li>• Damaged Thermal Print Head</li> </ul>
Premature Wear of Thermal Print Head	<ul style="list-style-type: none"> <li>• Printing with paper not approved by Syntest</li> <li>• Printing in an environment where abrasive particulate is allowed to enter the print mechanism</li> </ul>

### **6.5 Maintenance Chart**

The following chart represents a recommended maintenance schedule for the SP-328 printer. Specific environmental conditions may shorten or lengthen the periods between cleaning.

Clean Office or Light Use	Once Per Year
Clean Factory Environment Medium Use	Monthly
Dirty Factory Environment Heavy Use	Weekly

## APPENDIX

### Appendix A. ASCII Codes

Listed below are the printable ASCII characters for the SP-328. Decimal and Hexadecimal values are given.

Dec	Hex	Char	Dec	Hex	Char	Dec	Hex	Char	Dec	Hex	Char
32	20	SP	56	38	8	80	50	P	104	68	h
33	21	!	57	39	9	81	51	Q	105	69	i
34	22	"	58	3A	:	82	52	R	106	6A	j
35	23	#	59	3B	;	83	53	S	107	6B	k
36	24	\$	60	3C	<	84	54	T	108	6C	l
37	25	%	61	3D	=	85	55	U	109	6D	m
38	26	&	62	3E	>	86	56	V	110	6E	n
39	27	'	63	3F	?	87	57	W	111	6F	o
40	28	(	64	40	@	88	58	X	112	70	p
41	29	)	65	41	A	89	59	Y	113	71	q
42	2A	*	66	42	B	90	5A	Z	114	72	r
43	2B	+	67	43	C	91	5B	[	115	73	s
44	2C	,	68	44	D	92	5C	\	116	74	t
45	2D	-	69	45	E	93	5D	]	117	75	u
46	2E	.	70	46	F	94	5E	^	118	76	v
47	2F	/	71	47	G	95	5F	_	119	77	w
48	30	0	72	48	H	96	60	`	120	78	x
49	31	1	73	49	I	97	61	a	121	79	y
50	32	2	74	4A	J	98	62	b	122	7A	z
51	33	3	75	4B	K	99	63	c	123	7B	{
52	34	4	76	4C	L	100	64	d	124	7C	
53	35	5	77	4D	M	101	65	e	125	7D	}
54	36	6	78	4E	N	102	66	f	126	7E	~
55	37	7	79	4F	O	103	67	g	127	7F	DEL

## Appendix B PRINTER SPECIFICATIONS

<b>SPECIFICATION</b>	<b>MECHANISM</b>
Printing Method	Fixed Head Thermal
Character Composition	Dot matrix characters Ex. 11 x 28 matrix
Paper Width	2.350"
Head Density	8 dots per mm
Maximum Printing Speed	1.3 inches per second
Number of Printable Columns	40 columns
Paper Feed System	Friction feed system
Print Head Temperature	Detected by internal thermister
Paper Detection	Detected by internal optical sensor
Printing Voltage	24 VDC $\pm$ 10%
Logic Voltage	Generated via an on board switching regulator
Paper Feed Force	0.98N (100g min.)
Running Noise	55 dB maximum
Weight	4.5 Lbs
Print Head Life	90Km (54 Miles) of paper travel

# APPENDIX C Dimensions

**telpar, inc.**  
The Printer Solutions Company

# SP-328 Data Logger Thermal Printer

## Dimensions

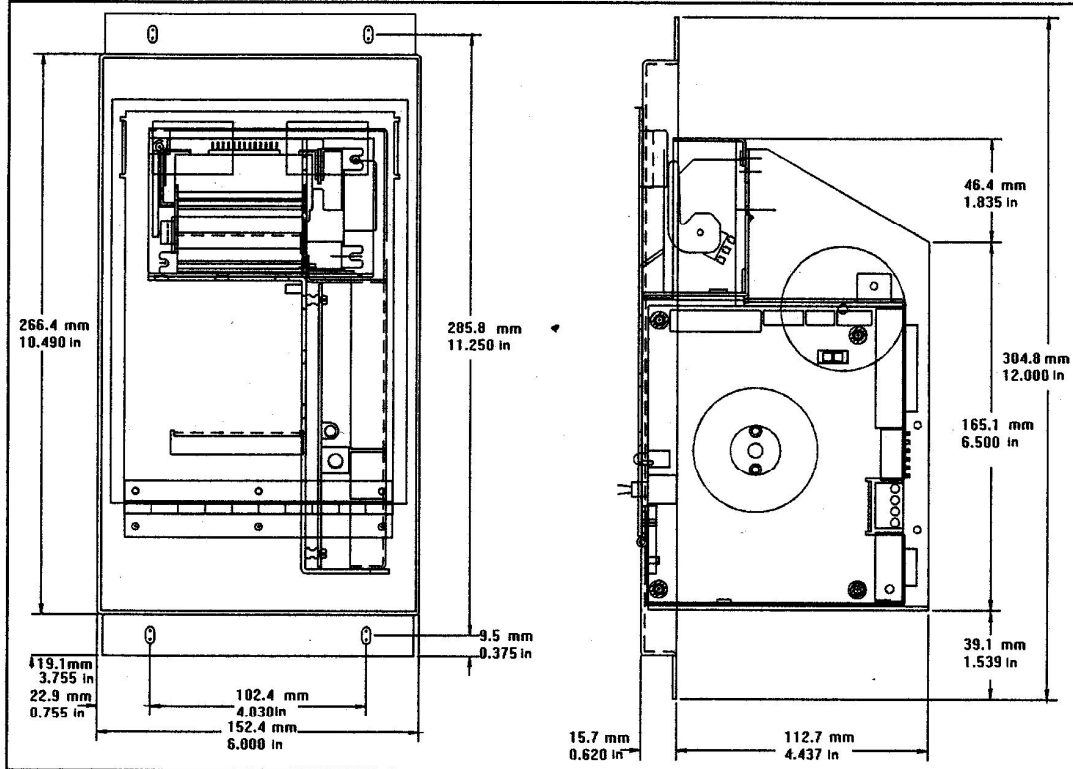

## Specifications

- Operating Temperature: 0° C to 50° C (32° F to 122° F)
- Storage Temperature: -20° C to 60° C (-4° F to 140° F)
- Humidity: 90% max. RH (non-condensing)
- Paper diameter: 76 mm (3.00 in)
- Paper thickness: 0.08 mm to 0.10 mm (.003 in to .004 in)
- Abrasion life: 90 km (54 miles)
- Serial RS-232C, 9600 baud via DB9 connector
- DTR flow control
- Centronics type parallel.

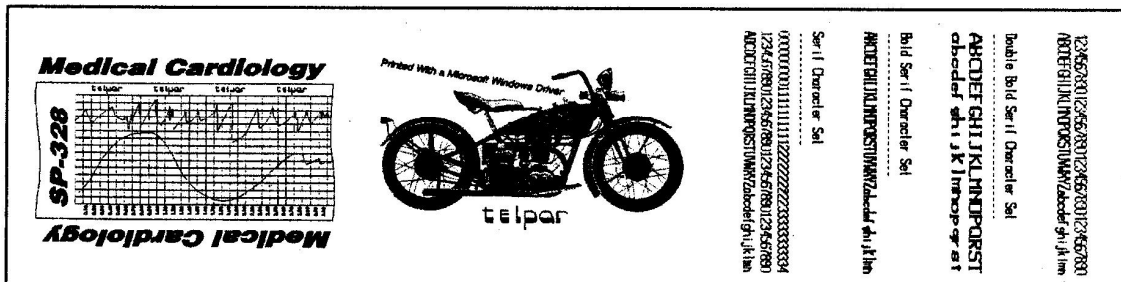

Specifications subject to change without notice

Actual print sample (not to scale)

Telpar, Inc.